

PENALTY SHOT

FOOTBALL GAME MANUAL



DX



SD

STOP

IMPORTANT

PLEASE READ THE MANUAL CAREFULLY AND KEEP IT IN MIND BEFORE USING THIS MACHINE

PUT THIS MANUAL WITHIN TOUCH OF YOUR REFERENCE IN ANYTIME.



TABLE OF CONTENTS

1. PRECAUTIONS

- a . Precautions before Installation.
- b. Product Assembly Precautions.
- c. Moving & Handling Precautions.
- d. Management after installation.
- e. Precautions during operation.

2. PRODUCT SPECIFICATION

3. TYPES OF PCBS & CIRCUIT DIAGRAMS

- a Main PCB.
- b. Power PCB.
- c. FND PCB
- d. LED LAMPS
- e. PCB Circuit Diagrams

4. GAME MODE SETTING

5. PARTS LIST

6. PRODUCT ASSEMBLY INSTRUCTION

7. A/S

- a How to change the ball
- b. How to change the ball poll
- c. In case when the ball tension is too loose or too tight...
- d. In case when the machine does not recognize the score...
- e. How to install the safety hitting cover



1. PRECAUTIONS

A. PRECAUTIONS BEFORE INSTALLATION

- P Please make sure the power voltage & frequency requirements are compatible with the product installation location.
(A fire or electric shock can be caused if the proper voltage & frequency are not used.)

B. PRODUCT ASSEMBLY PRECAUTIONS

- P Please get help from a specialist to assemble the product.
- P Please follow the steps and instructions from the manual.
- Make sure to use the indoor cables that are compatible with the power consumption specification.
(A fire or electric shock can be caused if the proper power consumption cables are not used)
- Make sure to use an independent power supply equipped with a surge-suppressor.
(A fire can be caused if a power supply is used without a surge-suppressor.)
- Please avoid putting the cables on the passageway.
(People may fall from trapping the cables.)

C. MOVING & HANDLING PRECAUTIONS

- P Make sure not to damage the power cables when moving the product.
(Damaged power cables can cause major product defects.)



1. PRECAUTIONS

D. MANAGEMENT AFTER INSTALLATION

P Please note that using balls other than Genuine Andamiro Soccer ball may cause damage to Shooting Chance.

E. PRECAUTIONS DURING OPERATION

P Excessive actions may cause injury.

P Do not drink and play.

- Please kick the ball safely to avoid injury or any other accidents.
- Be sure not to kick the machine and the safety hitting cover.
- Be sure to wear a shoe when kicking the ball.
- Do not stand on the ball or machine.

2. PRODUCT SPECIFICATION

- Power Voltage(AC) : 110V/220V compatible
- Power consumption : 800W

■ Product Size(mm) & Weight(kg)

– DX

Size : 900(W) x 1,100 (D) x1,980(H)
Weight : 160kg



– SD

Size : 700(W) x 1,100 (D) x1,850(H)
Weight : 100kg



3. TYPES OF PCBS & CIRCUIT DIAGRAMS

A. MAIN PCB

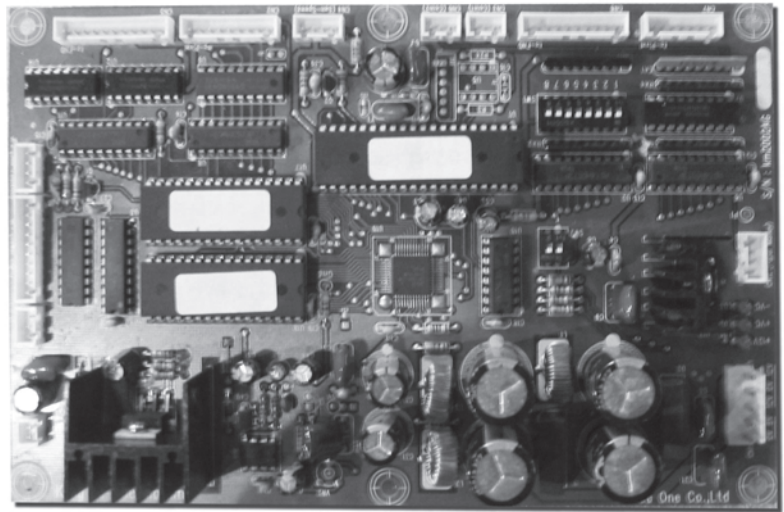

B. POWER PCB

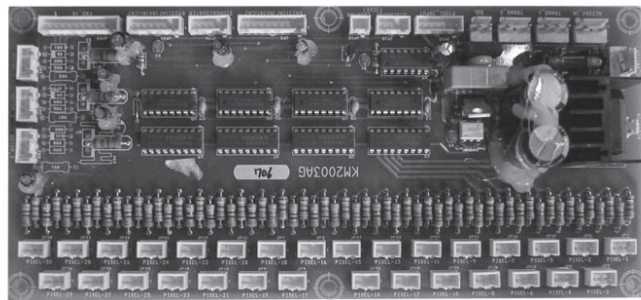

C. FND PCB

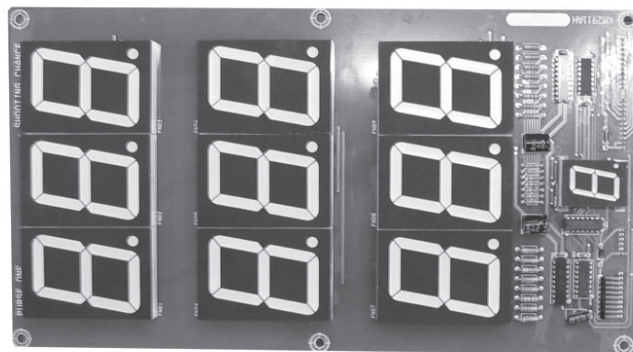

D. LED LAMPS

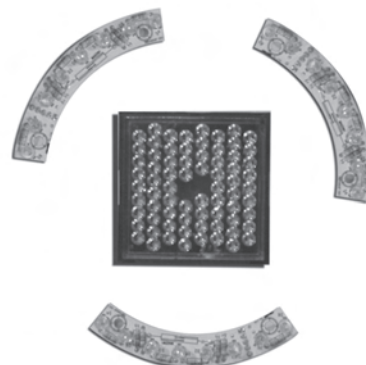

3. TYPES OF PCBS & CIRCUIT DIAGRAMS

E. PCB Circuit Diagrams

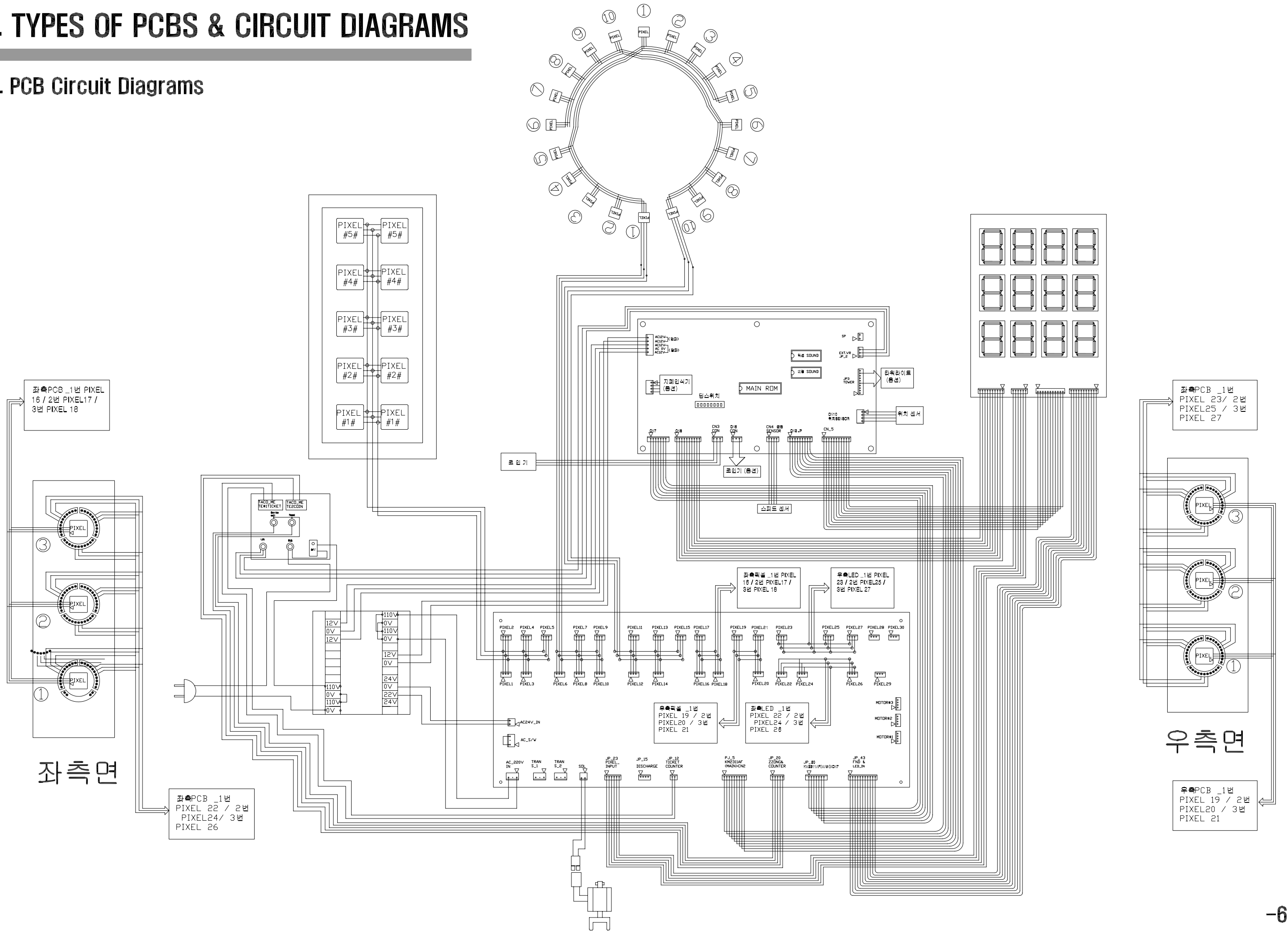



4. GAME MODE SETTING

SHOOTING CHANCE...DIP SWITCH #1								
	1	2	3	4	5	6	7	8
1 COIN / 1 CREDIT	OFF	OFF	OFF					
1 COIN / 2 CREDIT	ON	OFF	OFF					
2 COIN / 1 CREDIT	OFF	ON	OFF					
2 COIN / 2 CREDIT	OFF	OFF	ON					
2 COIN / 3 CREDIT	ON	ON	OFF					
3 COIN / 1 CREDIT	ON	OFF	ON					
3 COIN / 2 CREDIT	OFF	ON	ON					
3 COIN / 3 CREDIT	ON	ON	ON					
Final mecry ticket (first game not apply)	0				OFF	OFF		
	2				ON	OFF		
	4				OFF	ON		
	8				ON	ON		
Ticket per high score (every game apply)	0					OFF	OFF	
	10					ON	OFF	
	20					OFF	ON	
	30					ON	ON	
Jack pot ticket	0							OFF
	100							ON

SHOOTING CHANCE...DIP SWITCH #2		
	1	2
DEMO SOUND OFF	OFF	
DEMO SOUND On	ON	

- back up function is always ON.
- the high score is deducted by one point every play.
- DIP SWITCH 4~8 ALL OFF – AMUSEMENT GAME (BONUS GAME)



5. PART LIST

SHOOTING CHANCE... PART		QUANTITY
PCB	MAIN PCB	1EA
	POWER PCB	1EA
	FND PCB	1EA
Soccer Ball		2EA
Soccer Ball Poll		2EA
Bearing 206		2EA
Location Sensor / Speed Indication Sensor		1EA/1EA
Rectangular LED		36EA
Urethane Safety Cover (3 types)		1EA
Spring (Large / Small)		1EA/1EA
Coin meter / Ticket meter		1EA/1EA
Front LED Lamp RoundCase		6EA
Sticker		1EA
Front PC Print		2EA
Speaker		1EA
Key		2EA
Wire		1SET
Rubber Pad		1EA
3k Solenoid 3k		1EA

6. PRODUCT ASSEMBLY INSTRUCTION

A. CONNECTING THE FRONT CABINET & MAIN CABINET

1. Connect the cable sockets (Solenoid, Location Sensor, and LED) between the Kick Console & Main Console.
2. Connect and fix the Kick Console & Main Console by using 8mm bolts (14 in total).

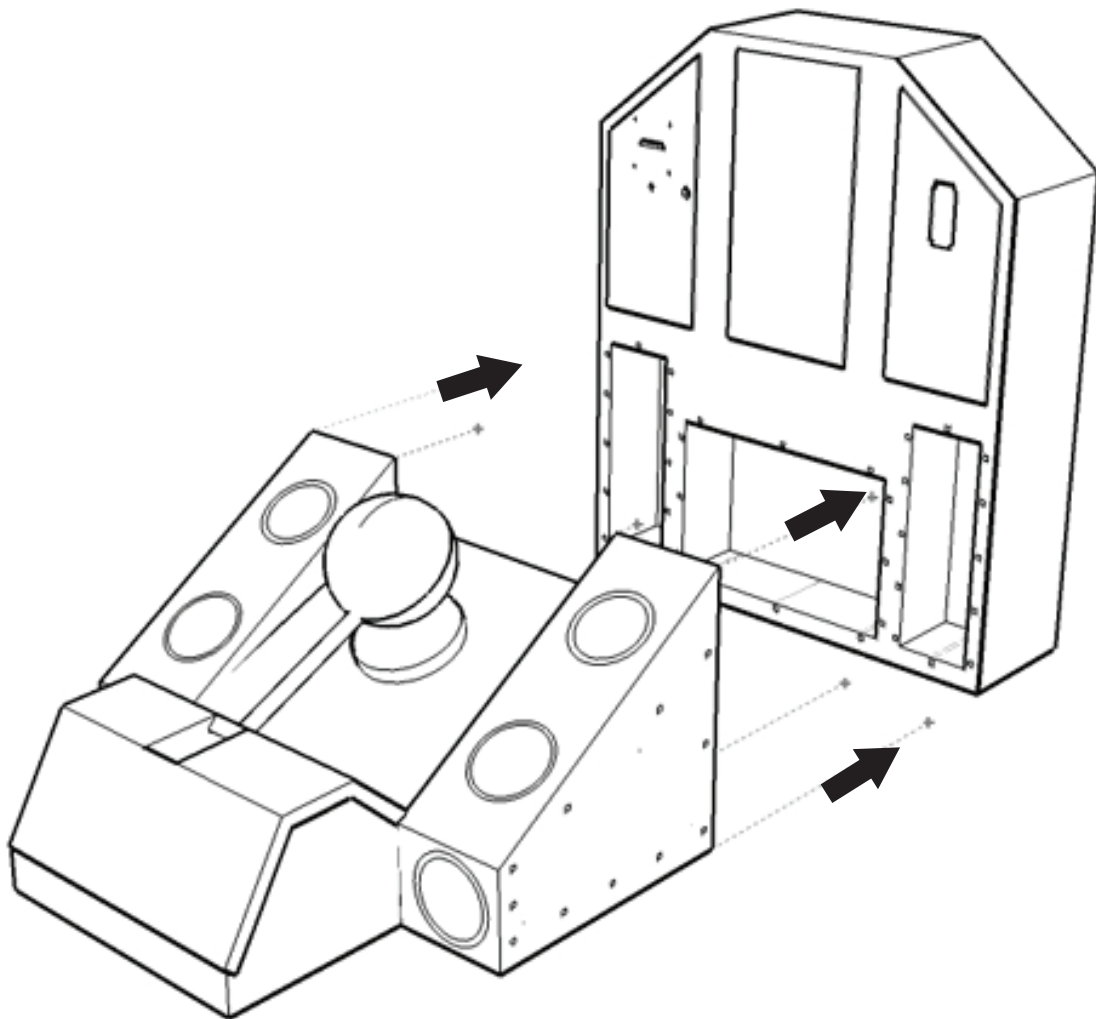

6. PRODUCT ASSEMBLY INSTRUCTION

B. CONNECTING THE TOP CIRCLE BOARD & MAIN CONSOLE

1. Connect the cables (total 4) from the main cabinet to the FND PCB of the Top Circle Board.
2. Connect the cables (total 2) from the main cabinet to the LED Lamp Sockets as picture shown.
3. Connect and fix the Top Circle Board & Main Console by using 8mm bolts. (6 in total).

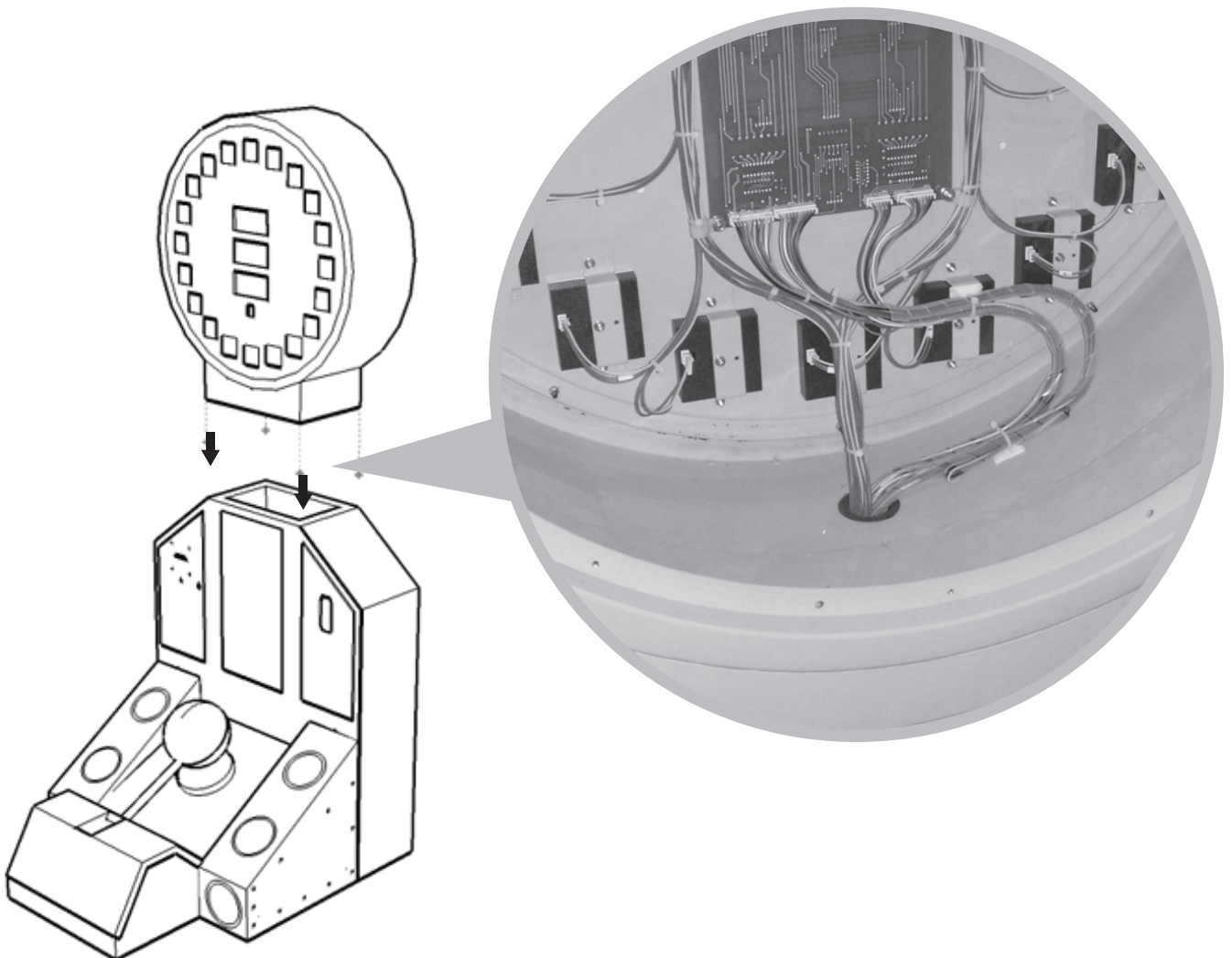

6. PRODUCT ASSEMBLY INSTRUCTION

C. COMPLETE ASSEMBLY LOOK

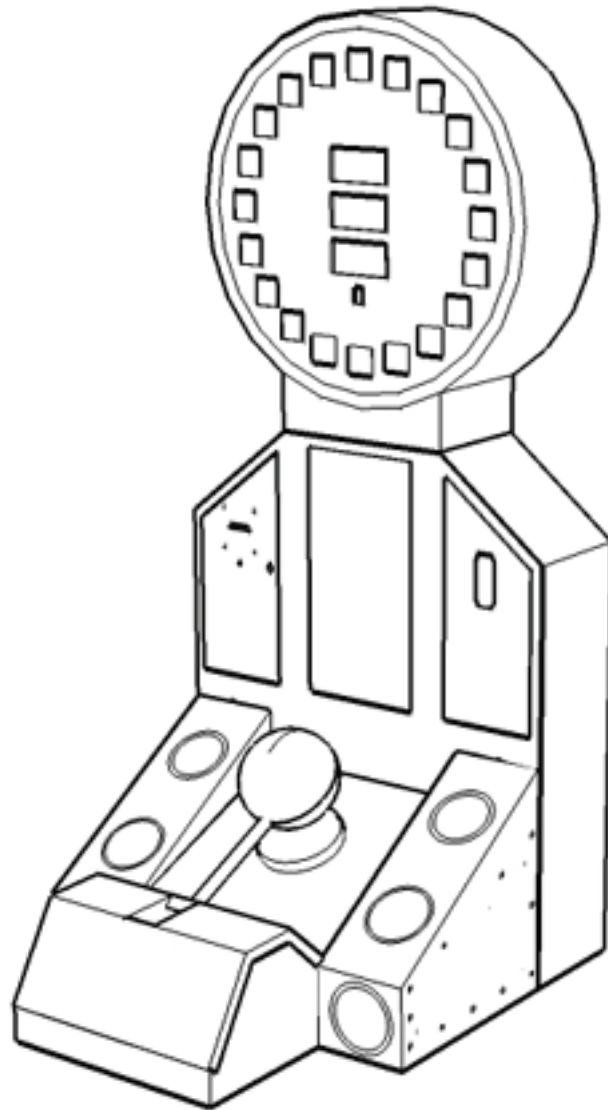

A. HOW TO CHANGE THE BALL



1. Remove the 8mm bolts (total 5) from the ball connector by using 13mm wrench.
2. Remove the Ball.
3. Replace a new ball to the origin.
4. Tie the bolts.

Tip to use the ball for a longer period of time, re-locate the ball clock-wise constantly depends on the ball condition.

B. HOW TO CHANGE THE BALL POLL

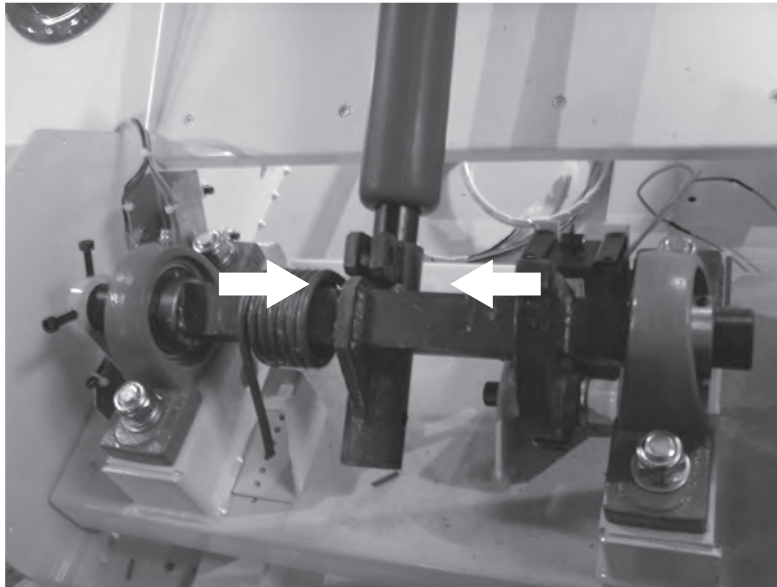

1. Remove the bolt (10mm) from the ball connecting assembly by using 17mm wrench.

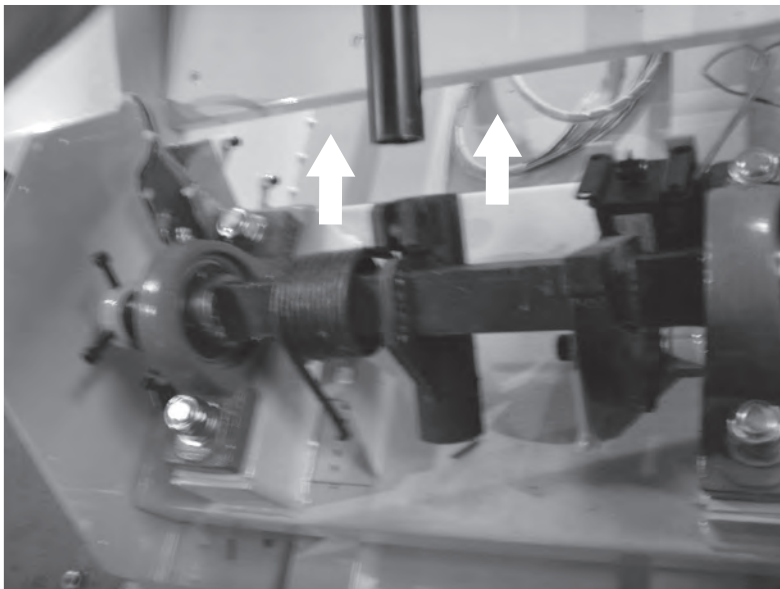

2. Remove the ball poll carefully from the ball connecting assembly.

** Please follow the Reverse-order to replace the new ball poll.

C. IN CASE WHEN THE BALL TENSION IS TOO LOOSE OR TOO TIGHT...

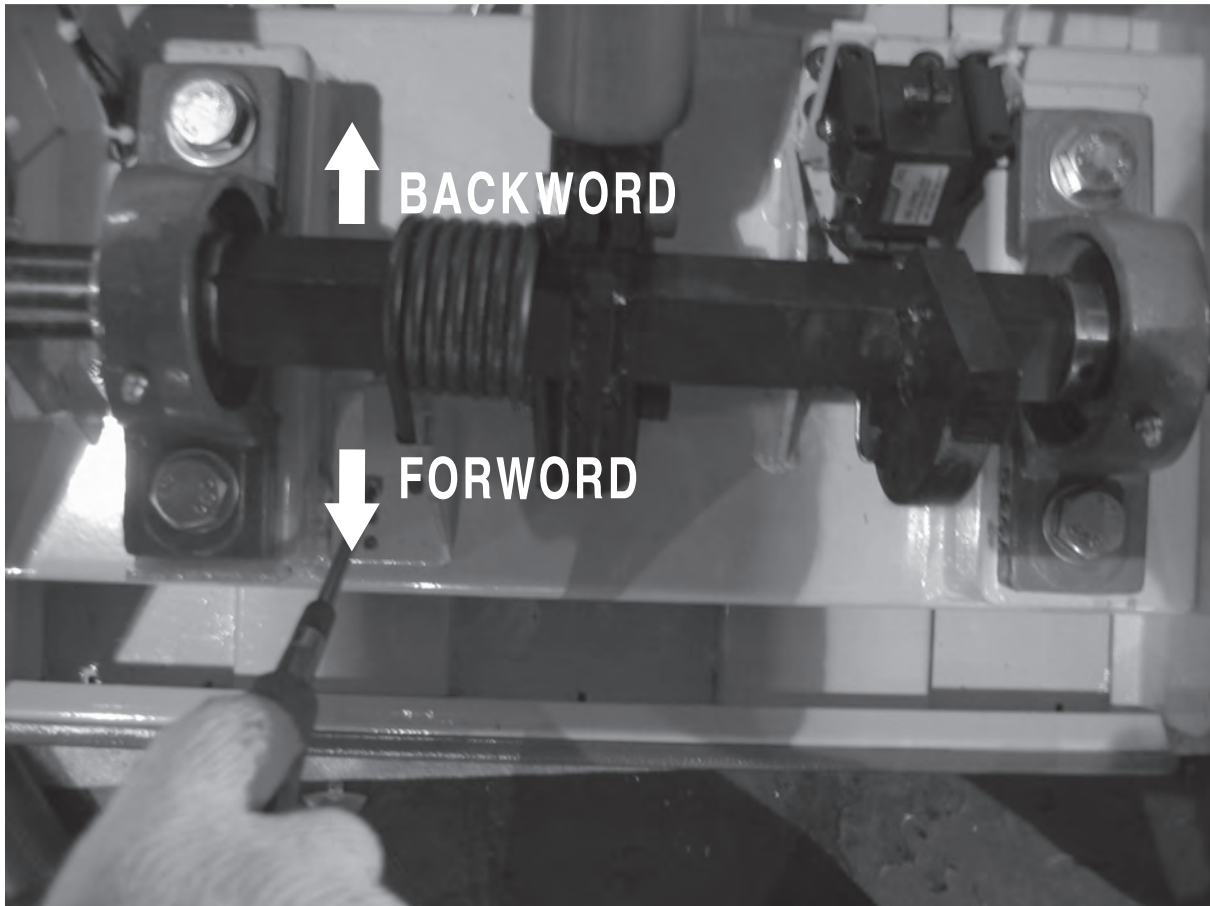

1. If the ball tension is too loose, move the tension control one level **BACKWORD** to make the tension **TIGHT**.
2. If the ball tension is too tight, move the tension control one level **FORWORD** to make the tension **LOOSE**.

D. IN CASE WHEN THE MACHINE DOES NOT RECOGNIZE THE SCORE...

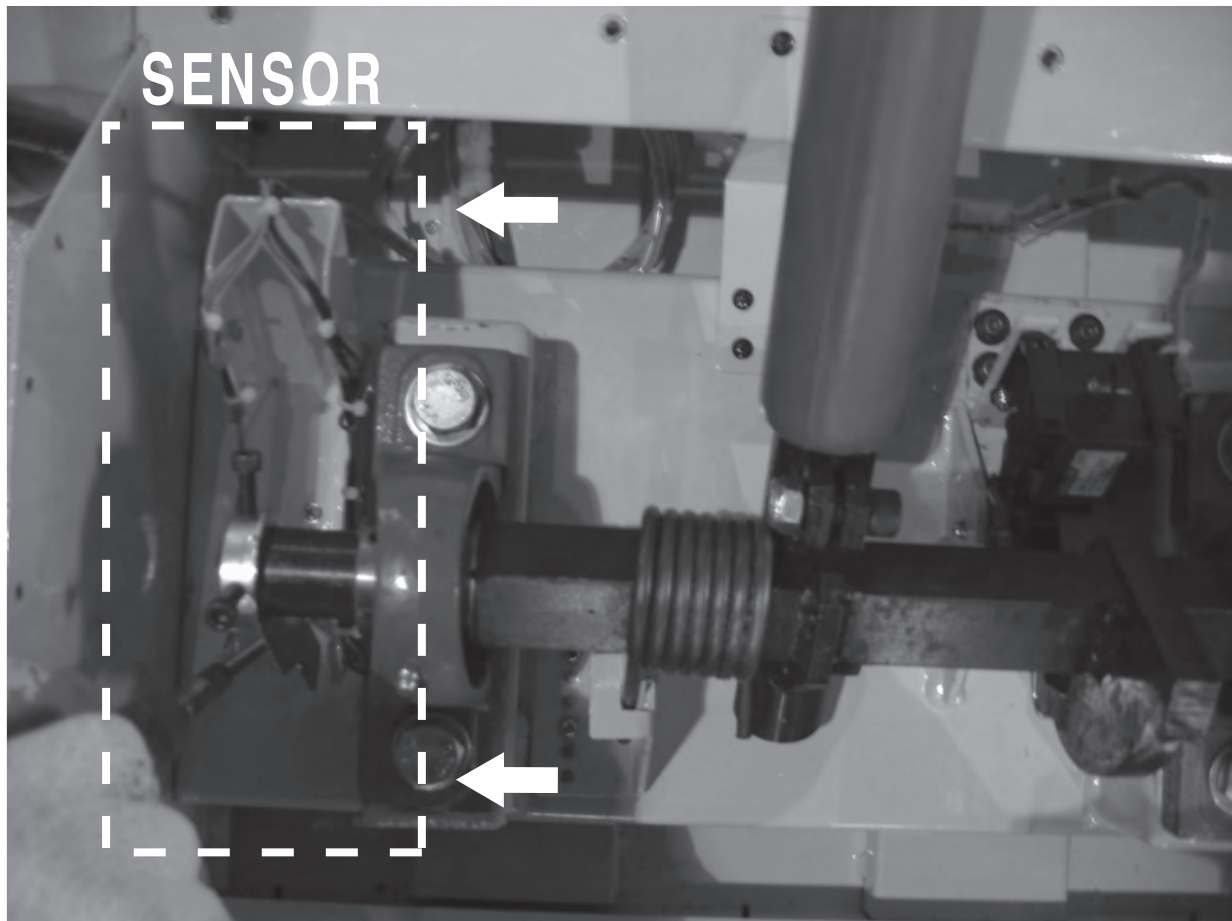

- ▶ Change the sensor bracket by removing 2 bolts shown in the picture above.

E. HOW TO INSTALL THE SAFETY HITTING COVER



1. Place the bottom of the cover first then fit the upper part of the cover.
2. Use the 4mm round head bolts (total 14) for the both sides, use 6mm hex washer (total 4) for the top side.

PENALTY SHOT

ANDAMIRO[®]
ENTERTAINMENT

**ANDAMIRO CO.LTD (ANDAMIRO KOREA)
COOPERATED PARTNER : PURSE ONE**

615-5 Changhang-Dong, Ilsan-Gu, Koyang-Si, 410-380 Kyonggi, Korea
Tel. 82-31-909-2100 / Fax. 82-31-908-7548 / email. info@andamiro.com